

Documentation

HiPath 500, HiPath 2000, HiPath 3000, HiPath 5000
HiPath 4000, HiPath OpenOffice ME

OpenStage 40

OpenStage 40 T

Quick Reference Guide



Communication for the open minded

Siemens Enterprise Communications
www.siemens.com/open

SIEMENS

Using Your Telephone

Function Keys and Audio Keys

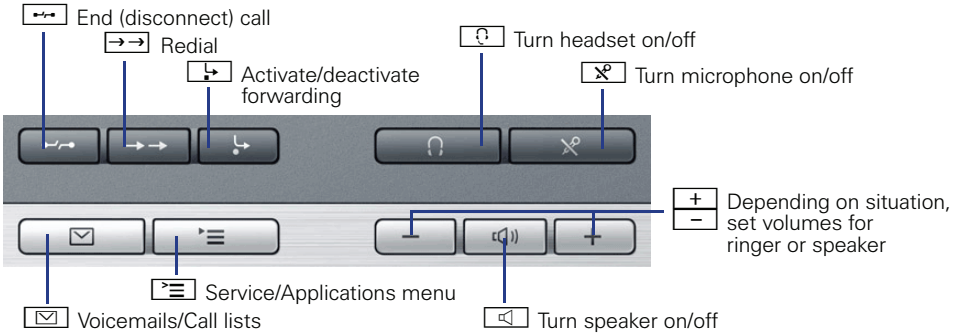

5-way navigator

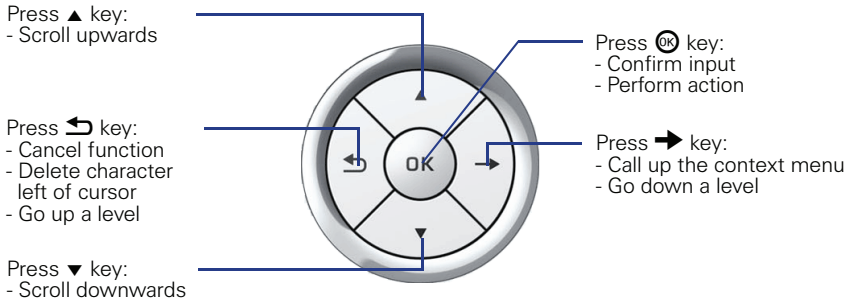

Programmable sensor keys on the display



Display

Components

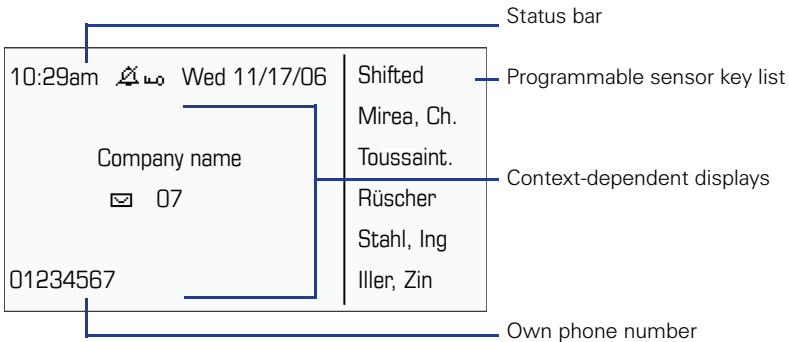



Entering Phone Numbers and Text









Keypad

In situations where text entry is possible, you can use the dial keys to enter text, punctuation and special characters. To do this, press the numerical keys repeatedly.

Extra asterisk and pound key functions:

Key	Function during text input	Function when held down
	Write special characters	Deactivate the ring tone.
	Switch between upper/lower case and digit entry.	Activate telephone lock.

Important Operating Procedures

 Lift handset	 Enter text or number
 Replace handset	 Select entry
 Conduct call	 Open context menu
 Ring tone/call waiting tone	 Next step in procedure

HiPath 4000

In Idle State





Answering a call with the handset







Answering a call in speakerphone mode





















Dialing from the caller list

→ "Unanswered calls?", "Incoming calls?" or "Outgoing calls?"  ▷  Select call 
 ▷  "Call Server?" 



Activating callback

 destination phone number  ▷ if no answer or busy:  "Callback?" 





Saving a phone number to a key

 Hold down programmable key ▷  "Change?"  ▷  "Redial?" 
 ▷  "Save?"  ▷  ▷  "Prog./Serv."  ▷  "Use speed dialing?" 
 ▷  press programmable key ▷ "Enter new number?"  ▷  phone number
 ▷ "Completed?"  ▷ "Use Destination Number?"  ▷ "Save?" 

Dialing a saved number

 saved phone number ▷  loudspeaker turns on automatically or 







Saving a function to a key

 Hold down programmable key ▷ ◆ "Change?" 
 ▷ ◆ select desired function  ▷ ◆ "Save?" 

Redialing a number

 ▷ 

Programming call forwarding

 ▷ "Prog./Serv."  (TDM only) ▷ ◆ "Destinations?"  ▷ ◆ "Call forwarding?" 
 ▷ ◆ "Next forwarding type?"  ▷ repeat until the desired forwarding type appears in the display (Variable call forw., Fixed call forw., FWD-VAR-ALL-INT, FWD-VAR-ALL-EXT, FWD-VAR-BUSY-BOTH, FWD-VAR-RNA-BOTH or FWD-VAR-BZ/NA-BTH)
 ▷ ◆ "Enter destination:" ▷  phone number ▷ ◆ "Save?" 

Turning call forwarding (fixed call forwarding:) on/off for all calls







During Calls with a Party A

Switching to speakerphone mode

Hold down  ▷  (US only:  ▷ )





Consultation

◆ ▷ "Consultation?"  ▷  phone number for party B ▷  party B
▷ ◆ "Release and return?"  ▷  party A





Accepting call waiting

 Call waiting tone ▷ ◆ "Answer camp-on?"  ▷  party B
▷ ◆ "Release and return?"  ▷  party A

Start conference

◆ "Consultation"  ▷  phone number for party B ▷  party B ▷ ◆ "Conference?" 
▷  party A and B





Start conference on call waiting

 call waiting tone ▷ ◆ "Answer camp-on?"  ▷  party B ▷ ◆ "Conference?" 
▷  party A and B

Blind transfer

◆ "Consultation?"  ▷  destination phone number ▷ 

Transfer after consultation

◆ "Consultation?"  ▷  phone number for party B ▷  party B ▷ 

HiPath 500/2000/3000/5000, HiPath OpenOffice ME

In Idle State

Answering a call with the handset



Answering a call in speakerphone mode



Rejecting a call



Activating callback

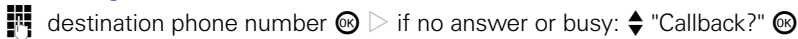

Saving a phone number to a key



Dialing a saved number

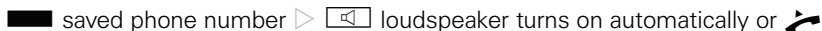

Saving a function to a key

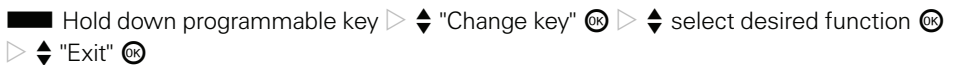

Redialing a number

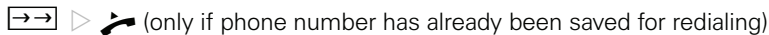

Programming call forwarding

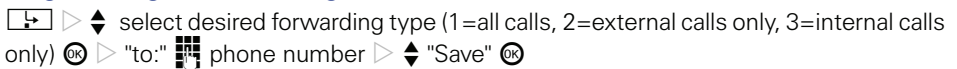

During Calls with a Party A





Switching to speakerphone mode

Hold down  ▷  (US only:  ▷ )

Consultation

◆ ▷ "Consultation"  ▷  phone number for party B
▷  party B ▷ "Quit and return"  ▷  party A



Start conference

◆ "Start conference?" or "Consultation?"  ▷  phone number for party B ▷  party B
▷ ◆ "Conference"  ▷  party A and B

Blind transfer

◆ "Consultation"  ▷  Dest. station no. ▷ 

Transfer after consultation

◆ "Consultation"  ▷  phone number for party B ▷  party B ▷ 

Reference No.:
A31003-S2000-U107-2-7619

Communication for the open minded

Siemens Enterprise Communications
www.siemens.com/open

© **Siemens Enterprise
Communications GmbH & Co. KG**
Hofmannstr. 51,
D-81359 München

The information provided in this document contains merely general descriptions or characteristics of performance which in case of actual use do not always apply as described or which may change as a result of further development of the products. An obligation to provide the respective characteristics shall only exist if expressly agreed in the terms of contract. Subject to availability. Right of modification reserved. The trademarks used are owned by Siemens Enterprise Communications GmbH & Co. KG or their respective owners.